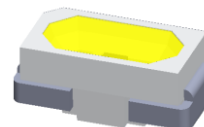

Approval Sheet

RoHS

Product : 3014 White SMD LED**Part Number :** LT-3014CT1-W0E-0-C**Customer :****Issue Date :** 2010/07/29

Feature

- High brightness Top view LED
- Dice Technology : InGaN
- Small package outline (LxWxH) of 3.0 x 1.4 x 1.2 mm
- Wide viewing angle (Lambertian Emitter)
- Top Diffusion Lens
- No UV
- Qualified according to JEDEC moisture sensitivity Level 3

Applications

- Portable flashlight
- Reading lights
- Security / garden lighting
- General lighting
- Indoor and outdoor commercial lighting

MAKER			CUSTOMER			
Prepared	Checked	Approved				

Part Code

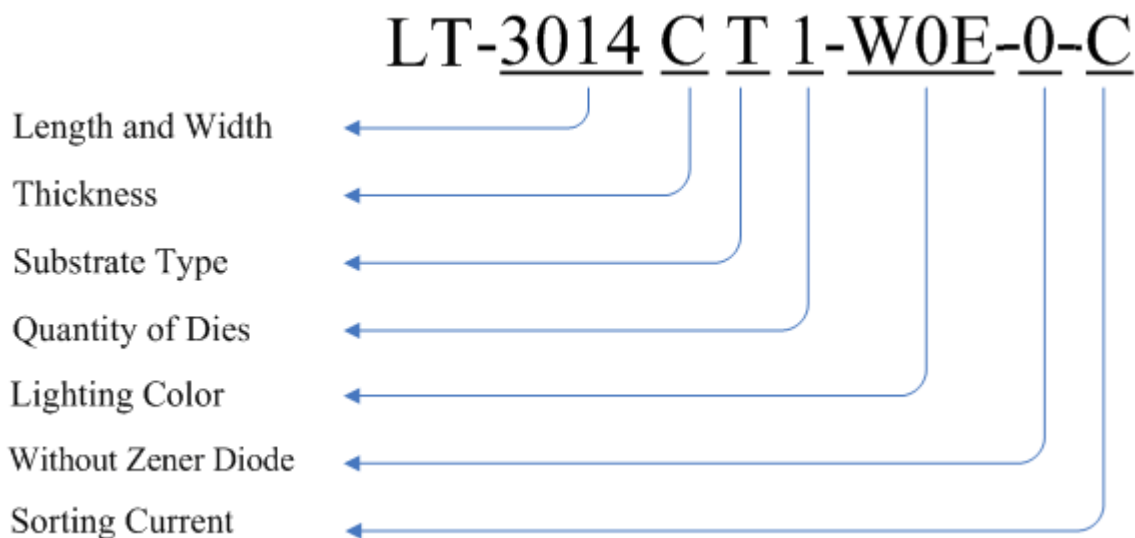

Opto-Electrical Characteristics

Ta=25°C

Parameter	Symbol	Condition	Min.	Typ.	Max.	Unit
Forward Voltage*	V _F	I _F = 20mA	2.8	-	3.6	V
CIE**	(x , y)	I _F = 20mA		WE series		
Correlated Color Temperature	CCT	I _F = 20mA	2670	-	7000	K
Luminous Intensity***	I _v	I _F = 20mA	1870	-	2850	mcd
Color Rendering Index		I _F = 20mA	-	-	70	
View Angle	θ	I _F = 20mA	-	119	-	deg.
Leakage current	I _r	-5V	-	-	2	μA

* The Forward Voltage tolerance is ±0.03V.

** Correlated color Temperature is derived from the CIE 1931 Chromaticity diagram.

*** The luminous intensity tolerance is ± 10%.

Outline Dimension & Recommended Solder Pattern

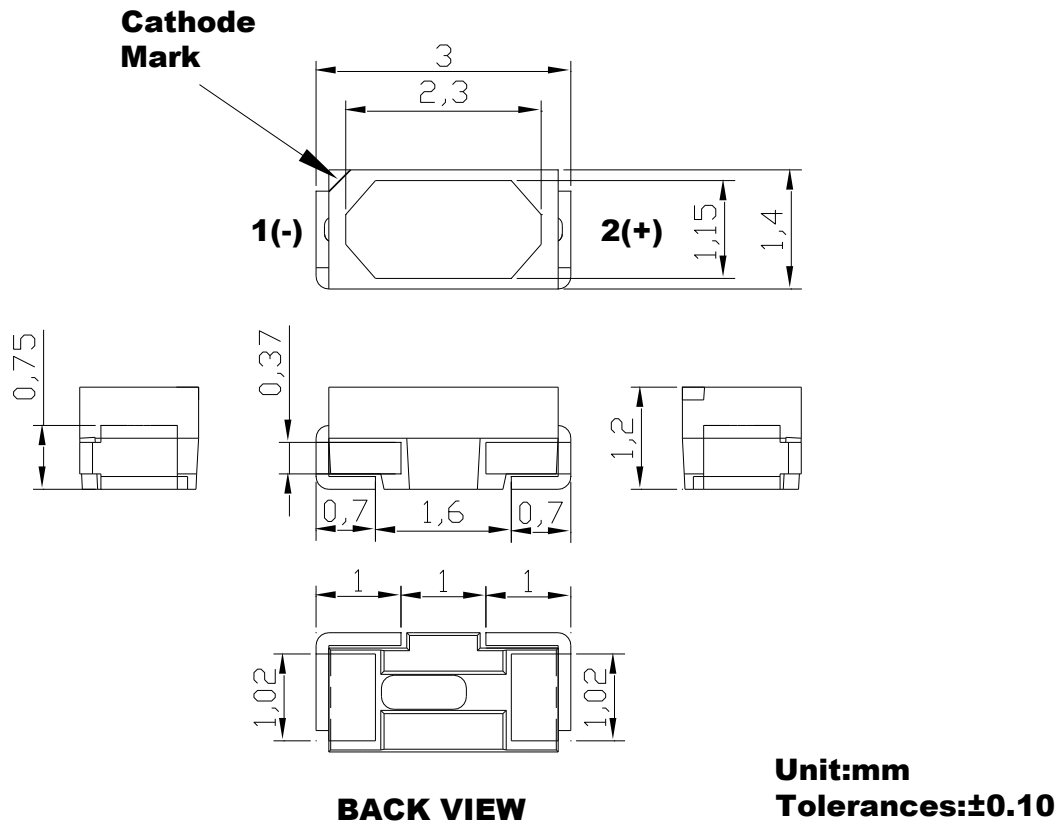

Recommended Pad

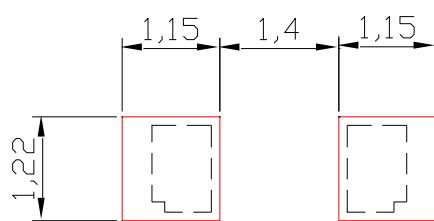

Pin connection

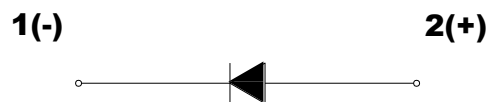

Pick-up Head Suggestion

	Symbol	Definition	Specification
LED	X1	the outside length of LED	2.7mm
	X2	the window length of LED	2.3mm
	Y1	the outside width of LED	1.4mm
	Y2	the window width of LED	1.15mm
TYPE I	X3	the outside length of Pick-up Head	*
	X4	the inside length of Pick-up Head	*
	Y3	the outside width of Pick-up Head	*
	Y4	the inside width of Pick-up Head	*
TYPE II	D	the outside diameter of Pick-up Head	**
	d	the inside diameter of Pick-up Head	**

* If use the Type I of pick-up head must accord with the following rule:

- 1.The outside length of Pick-up Head “X3” must bigger than the window length of LED “X2”.
- 2.The inside length of Pick-up Head “X4” must smaller than the outside length of LED “X1”.
- 3.The outside width of Pick-up Head “Y3” must bigger than the window width of LED “Y2”.
- 4.The inside width of Pick-up Head “Y4” must smaller than the outside width of LED “Y1”.

** If use the Type II of pick-up head must accord with the following rule:

- 1.The Pick-up Head outside diameter “D” must bigger than the width of LED “Y1”.
- 2.The Pick-up Head inside diameter “d” must smaller than the length of LED “Y2”.

The suggestion pick-up head is as same as follow the Sketch Map.

About the downward pressure of Pick-up Head, Please consult the Absolute Maximum Ratings.

LED Sketch Map

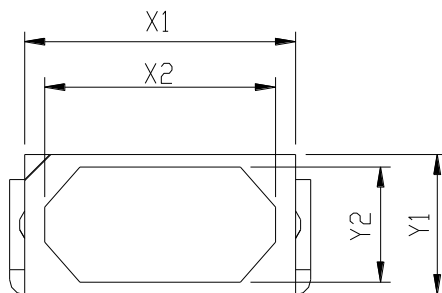

Pick-up Head Sketch Map

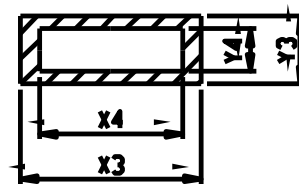

TYPE I

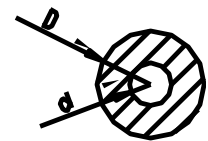

TYPE II

Spectrum Distribution

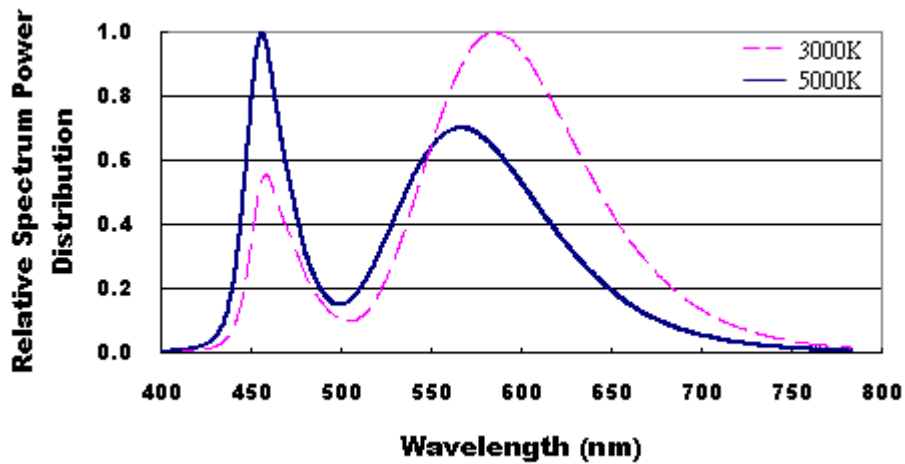

Forward Voltage vs. Forward Current

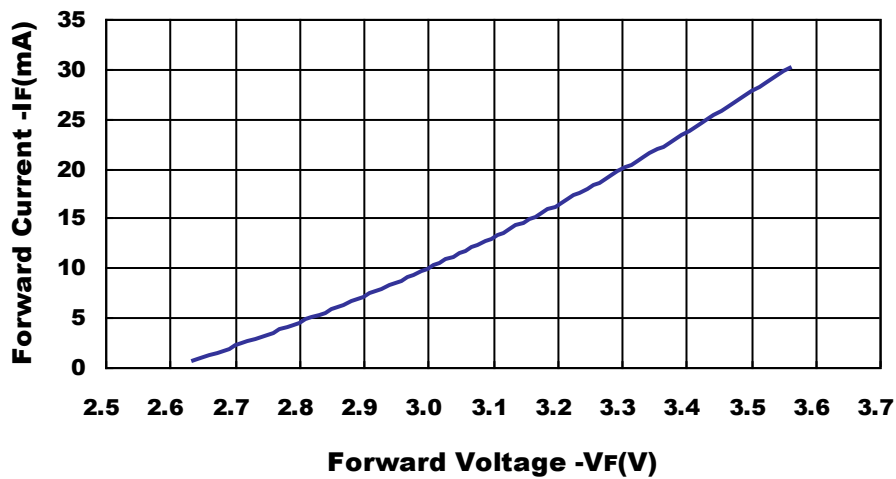

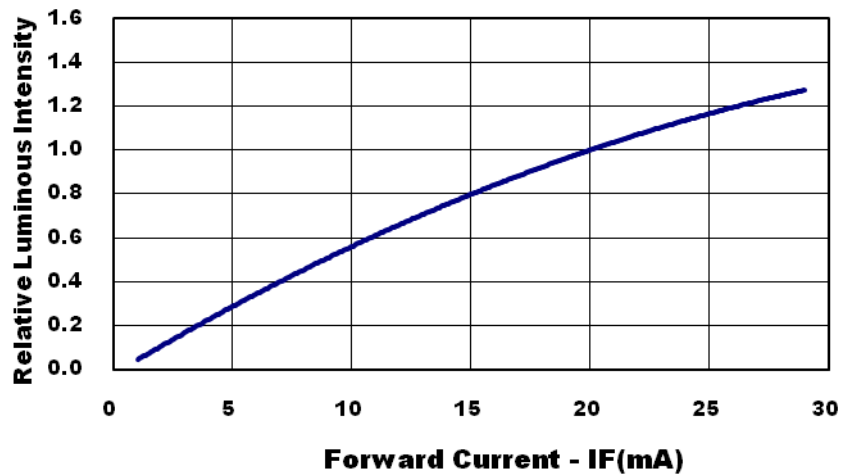
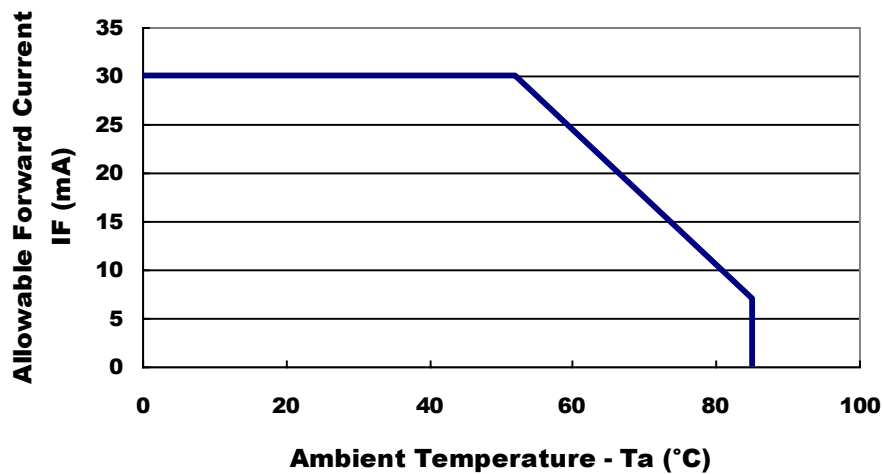
Forward Current vs. Relative Luminous Intensity***Ambient Temp. vs. Allowable Forward Current***

Radiation Pattern

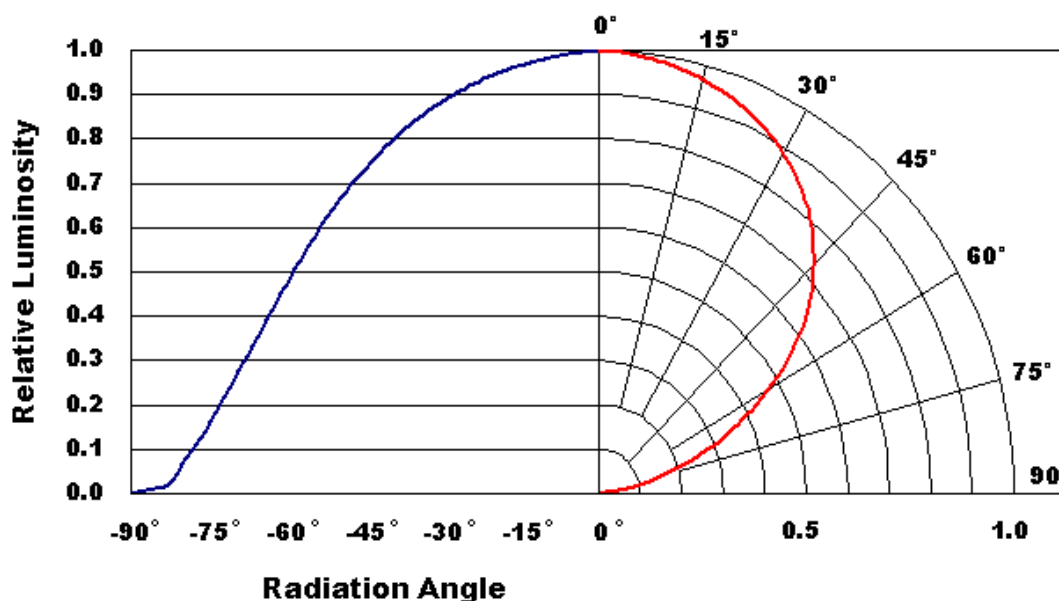

Absolute Maximum Ratings

Ta=25°C

Parameter	Symbol	Rating	Unit
Reverse Voltage	V _r	5	V
Forward Current	I _f	30	mA
Power Dissipation	P _d	110	mW
Pulse Forward Current*	I _{FP}	100	mA
Storage Temperature	T _s	-40 ~ +100	°C
Operation Temperature	T _{op}	-30 ~ +85	°C
Electrostatic Discharge(HBM)	ESD	1000	V
Allowable Pressure**	Pa	< 1	Kg/cm ²

* Condition : 1/10 duty, 10 msec width.

** LED allowable pressure value during SMT process.

Surface Mounting Condition

In the automatic mounting of the SMD LED to the PCB, any bending, expanding, and pulling forces against the SMD LED should be minimized to prevent the electrical failures or mechanical damaged.

Reflow Soldering and Temperature Profile

The SMD LED is designed for the reflow soldering process. Too high temperature or too large temperature gradient may cause the electrical and optical failures.

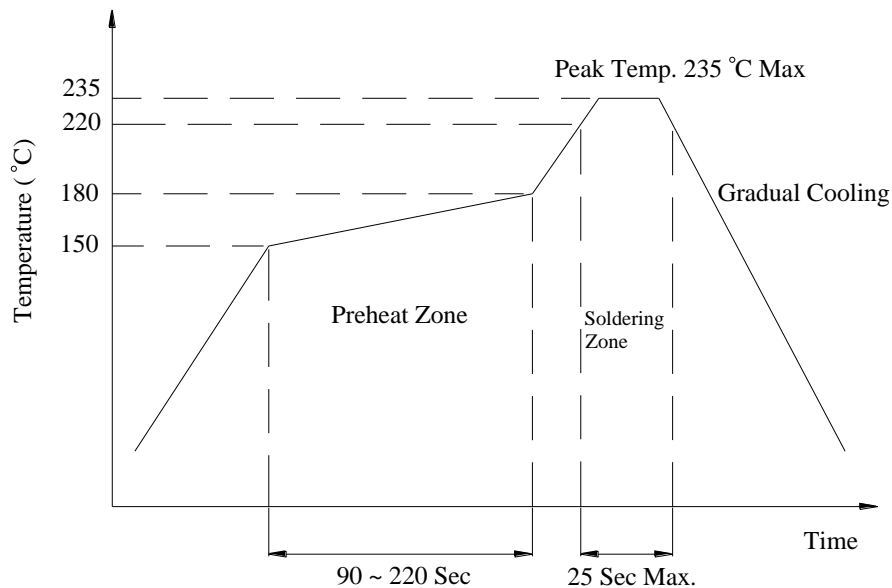
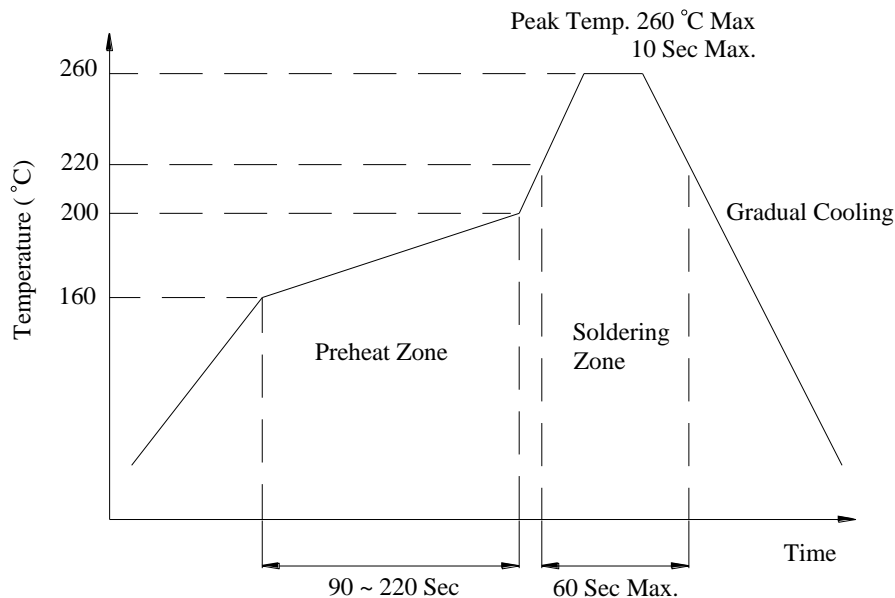
➤ Lead Solder**➤ Lead – Free Solder**

Reliability Test Items

<i>No</i>	<i>Item</i>	<i>Condition</i>	<i>Time/Cycle</i>	<i>Number of Damaged</i>
1.	<i>Soldering Heat Test</i>	260°C ± 5 °C	10 sec	0/60
2	<i>Thermal Shock</i>	0 °C(15 sec) ~ 100 °C(15 sec)	20 cycle	0/60
3	<i>High Temp. Storage</i>	100 °C	1000 Hrs	0/60
4	<i>Low Temp. Storage</i>	-40 °C	1000 Hrs	0/60
5	<i>Temperature Cycle Test</i>	-40 °C ~ 80 °C	100 Cycles, 200 Hrs	0/60
6	<i>High Temp. and Humidity Test</i>	60 °C, 90 % RH	1000 Hrs	0/60
7	<i>Operation Life Test 1</i>	Room Temp., 20 mA	1000 Hrs	0/60
8	<i>Operation Life Test 2</i>	Room Temp., 30 mA	500 Hrs	0/60
9	<i>High Temp. Operation Life Test</i>	85 °C, 5mA	1000 Hrs	0/60
10	<i>Low Temp. Operation Life Test</i>	-30 °C, 20mA	1000Hrs	0/60

Judgment Criteria

<i>Item</i>	<i>Symbol</i>	<i>Test Conditions</i>	<i>Judgment Criteria</i>
<i>Forward Voltage</i>	V _f	I _F = 20 mA	Δ % < 10 %
<i>Luminous Intensity</i>	I _v	I _F = 20 mA	Δ % < 30 %

CIE, Brightness, and Vf Classification

(Ta=25°C)

Color Temperature	CIE Code	Brightness (lv)	Vf
2670K 2850K	WEM1 WEM2 WEM3 WEM4 WEM5	1870 ~ 1970 mcd 1970 ~ 2070 mcd 2070 ~ 2180 mcd 2180 ~ 2290 mcd 2290 ~ 2400 mcd 2400 ~ 2550 mcd	2.8-3.6 0.1 V as one rank
2850K 3050K	WEN1 WEN2 WEN3 WEN4 WEN5		
3050K 3250K	WEP1 WEP2 WEP3 WEP4 WEP5		
3250K 3500K	WEQ1 WEQ2 WEQ3 WEQ4 WEQ5		
3500K 3800K	WER1 WER2 WER3 WER4 WER5		

<i>Color Temperature</i>	<i>CIE Code</i>	<i>Brightness (lv)</i>	<i>Vf</i>
3800K I 4100K	WES1	1970 ~ 2070 mcd 2070 ~ 2180 mcd 2180 ~ 2290 mcd 2290 ~ 2400 mcd 2400 ~ 2550 mcd 2550 ~ 2700 mcd 2700 ~ 2850 mcd	2.8-3.6 0.1 V as one rank
	WES2		
	WES3		
	WES4		
	WES5		
4100K I 4500K	WET1		
	WET2		
	WET3		
	WET4		
	WET5		
4500K I 5000K	WEU1		
	WEU2		
	WEU3		
	WEU4		
	WEU5		
5000K I 5650K	WEV1		
	WEV2		
	WEV3		
	WEV4		
	WEV5		
5650K I 6300K	WEW1		
	WEW2		
	WEW3		
	WEW4		
	WEW5		
6300K I 7000K	WEX1		
	WEX2		
	WEX3		
	WEX4		

* Luminous Intensity Measurement allowance is $\pm 10\%$.

Chromaticity Diagram

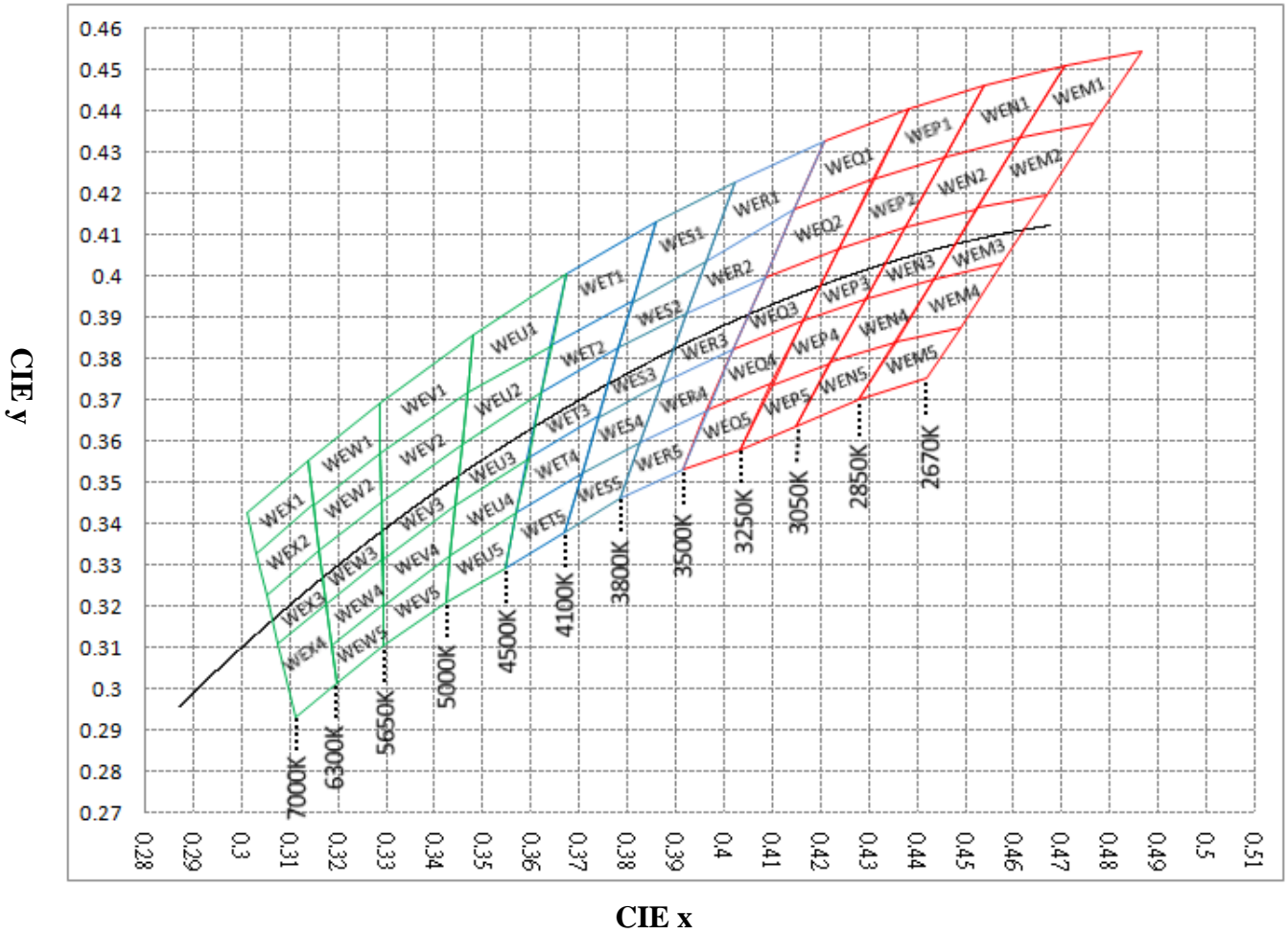

Correlated Color Temperature is derived from the CIE 1931 Chromaticity diagram.
 CCT measured tolerance is $\pm 5\%$.

Color Rank

WEM1		WEN1		WEP1		WEQ1	
0.4866	0.4542	0.4705	0.4508	0.4538	0.4460	0.4385	0.4404
0.4767	0.4366	0.4614	0.4333	0.4456	0.4287	0.4312	0.4234
0.4614	0.4333	0.4456	0.4287	0.4312	0.4234	0.4148	0.4161
0.4705	0.4508	0.4538	0.4460	0.4385	0.4404	0.4209	0.4326
WEM2		WEN2		WEP2		WEQ2	
0.4767	0.4366	0.4614	0.4333	0.4456	0.4287	0.4312	0.4234
0.4671	0.4196	0.4525	0.4162	0.4376	0.4116	0.4240	0.4065
0.4525	0.4162	0.4376	0.4116	0.4240	0.4065	0.4086	0.3995
0.4614	0.4333	0.4456	0.4287	0.4312	0.4234	0.4148	0.4161
WEM3		WEN3		WEP3		WEQ3	
0.4671	0.4196	0.4525	0.4162	0.4376	0.4116	0.4240	0.4065
0.4577	0.4029	0.4436	0.3991	0.4294	0.3943	0.4165	0.3890
0.4436	0.3991	0.4294	0.3943	0.4165	0.3890	0.4021	0.3822
0.4525	0.4162	0.4376	0.4116	0.4240	0.4065	0.4086	0.3995
WEM4		WEN4		WEP4		WEQ4	
0.4436	0.3991	0.4294	0.3943	0.4165	0.3890	0.4021	0.3822
0.4577	0.4029	0.4436	0.3991	0.4294	0.3943	0.4165	0.3890
0.4490	0.3875	0.4356	0.3837	0.4221	0.3790	0.4100	0.3738
0.4356	0.3837	0.4221	0.3790	0.4100	0.3738	0.3966	0.3673
WEM5		WEN5		WEP5		WEQ5	
0.4356	0.3837	0.4221	0.3790	0.4100	0.3738	0.3966	0.3673
0.4490	0.3875	0.4356	0.3837	0.4221	0.3790	0.4100	0.3738
0.4420	0.3750	0.4280	0.3700	0.4150	0.3635	0.4035	0.3580
0.4280	0.3700	0.4150	0.3635	0.4035	0.3580	0.3917	0.3530

WER1		WES1		WET1		WEU1	
0.4023	0.4228	0.3860	0.4130	0.3673	0.4003	0.3481	0.3856
0.4209	0.4326	0.4023	0.4228	0.3860	0.4130	0.3673	0.4003
0.4148	0.4161	0.3963	0.4035	0.3811	0.3937	0.3642	0.3829
0.3963	0.4035	0.3811	0.3937	0.3642	0.3829	0.3469	0.3717
WER2		WES2		WET2		WEU2	
0.3963	0.4035	0.3811	0.3937	0.3642	0.3829	0.3469	0.3717
0.4148	0.4161	0.3963	0.4035	0.3811	0.3937	0.3642	0.3829
0.4086	0.3995	0.3924	0.3909	0.3783	0.3825	0.3622	0.3716
0.3924	0.3909	0.3783	0.3825	0.3622	0.3716	0.3458	0.3592
WER3		WES3		WET3		WEU3	
0.3924	0.3909	0.3783	0.3825	0.3622	0.3716	0.3458	0.3592
0.4086	0.3995	0.3924	0.3909	0.3783	0.3825	0.3622	0.3716
0.4021	0.3822	0.3871	0.3739	0.3741	0.3658	0.3594	0.3557
0.3871	0.3739	0.3741	0.3658	0.3594	0.3557	0.3444	0.3442
WER4		WES4		WET4		WEU4	
0.3871	0.3739	0.3741	0.3658	0.3594	0.3557	0.3444	0.3442
0.4021	0.3822	0.3871	0.3739	0.3741	0.3658	0.3594	0.3557
0.3966	0.3673	0.3826	0.3595	0.3706	0.3520	0.3571	0.3426
0.3826	0.3595	0.3706	0.3520	0.3571	0.3426	0.3434	0.3320
WER5		WES5		WET5		WEU5	
0.3826	0.3595	0.3706	0.3520	0.3571	0.3426	0.3434	0.3320
0.3966	0.3673	0.3826	0.3595	0.3706	0.3520	0.3571	0.3426
0.3917	0.3530	0.3785	0.3460	0.3670	0.3377	0.3548	0.3290
0.3785	0.3460	0.3670	0.3377	0.3548	0.3290	0.3425	0.3208

WEV1		WEW1		WEX1	
0.3286	0.3690	0.3136	0.3550	0.3011	0.3422
0.3481	0.3856	0.3286	0.3690	0.3136	0.3550
0.3469	0.3717	0.3288	0.3569	0.3148	0.3444
0.3288	0.3569	0.3148	0.3444	0.3031	0.3327
WEV2		WEW2		WEX2	
0.3288	0.3569	0.3148	0.3444	0.3031	0.3327
0.3469	0.3717	0.3288	0.3569	0.3148	0.3444
0.3458	0.3592	0.3290	0.3451	0.3160	0.3332
0.3290	0.3451	0.3160	0.3332	0.3052	0.3224
WEV3		WEW3		WEX3	
0.3290	0.3451	0.3160	0.3332	0.3052	0.3224
0.3458	0.3592	0.3290	0.3451	0.3160	0.3332
0.3444	0.3442	0.3292	0.3313	0.3175	0.3204
0.3292	0.3313	0.3175	0.3204	0.3076	0.3108
WEV4		WEW4		WEX4	
0.3292	0.3313	0.3175	0.3204	0.3076	0.3108
0.3444	0.3442	0.3292	0.3313	0.3175	0.3204
0.3434	0.3320	0.3294	0.3202	0.3196	0.3013
0.3294	0.3202	0.3186	0.3102	0.3112	0.2932
WEV5		WEW5			
0.3294	0.3202	0.3186	0.3102		
0.3434	0.3320	0.3294	0.3202		
0.3425	0.3208	0.3295	0.3105		
0.3295	0.3105	0.3196	0.3013		

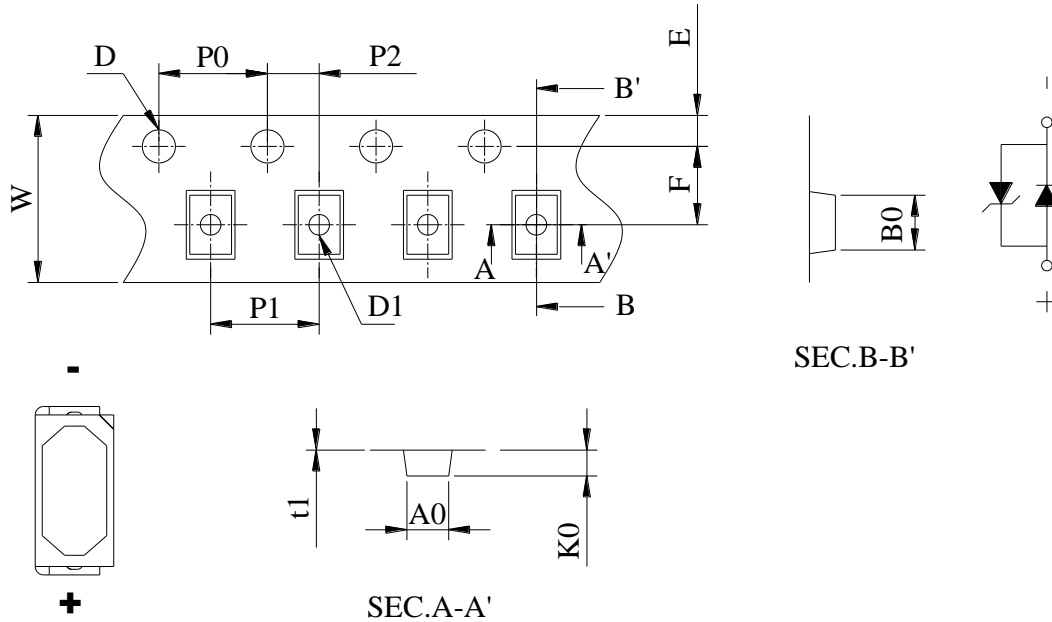

Carrier Tape



Unit : mm

Item	Spec	Tol.(+/-)	Item	Spec	Tol.(+/-)
W	8.00	±0.10	P2	2.00	±0.05
E	1.75	±0.10	P0 x 10	40.00	±0.20
F	3.50	±0.05	t1	0.23	±0.05
D	1.50	+0.1,-0	A0	1.50	±0.05
D1	1.00	±0.10	B0	3.20	±0.05
P0	4.00	±0.10	K0	1.48	±0.05

Reel Label

3014 White SMD LED	
Part Number	LT-3014CT1-W0E-0-C
	
Iv	xxxx - xxxx mcd
CIE Range	WExx - xxxx
Vf	xx - xx V
Serial No	xxxxxxxxxxxx Q'ty xxxx ea
	

RoHS

Package

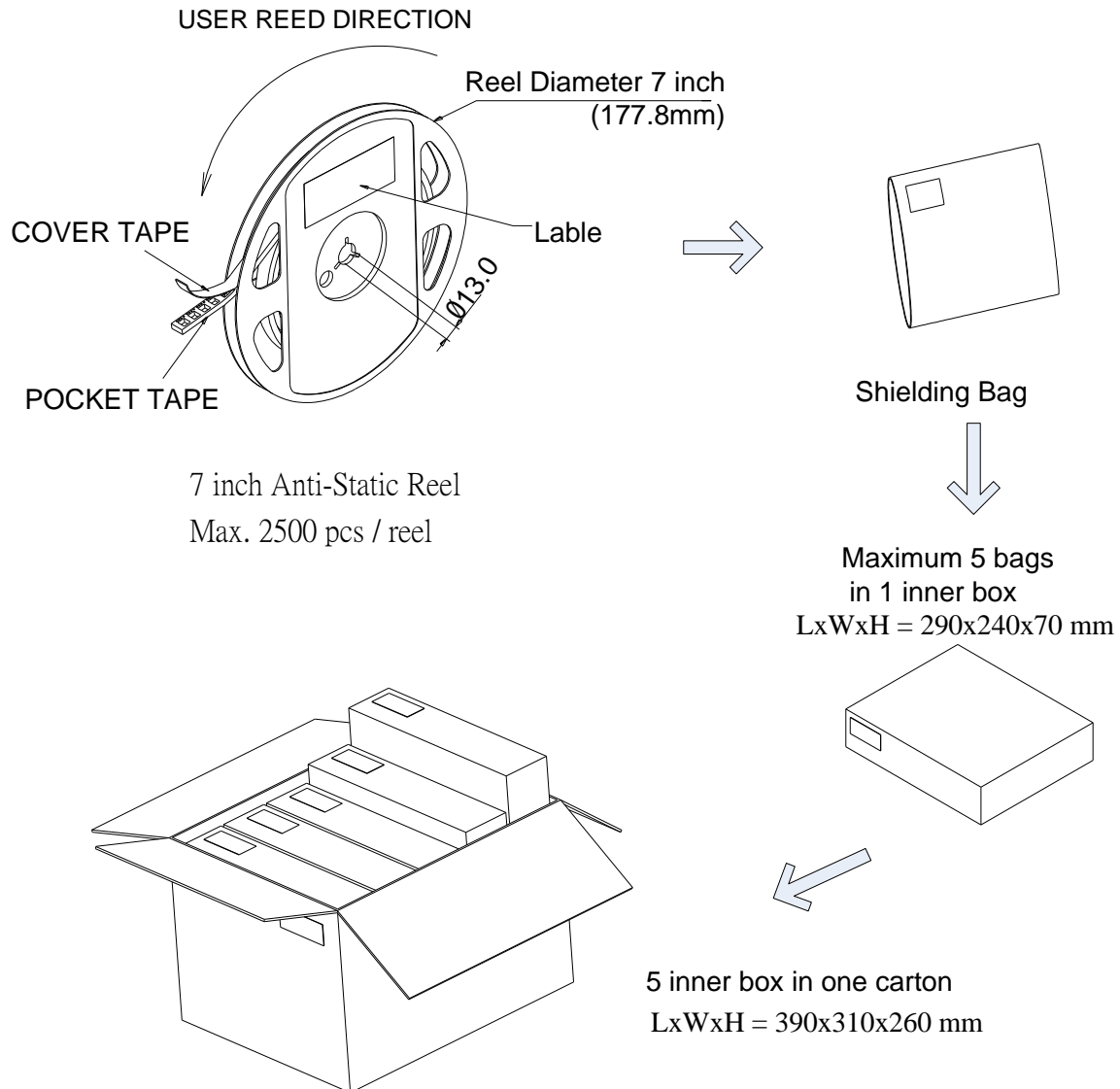

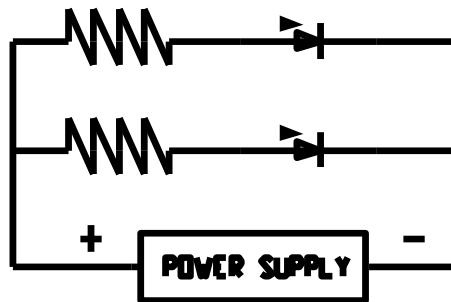
Recommend Circuit Design**Caution**

1. Before open the package, should kept at 30 °C, 90% RH environment or less, The LED should be used within a year.
2. After open the package, the LED should be kept at 30°C, 60 % RH environment or less. The LED should be soldered within 168 hours (7 days) after opening the package. If unused LEDs remain, they should be stored in moisture proof packages, such as sealed containers with packages of moisture absorbent material (silica gel).
3. The SMD LED is an ESD sensitive device. All the equipment and machine must be properly grounded.
4. Applying proper resistor for the circuit design is recommended. Otherwise slight voltage shift may cause big current change and the LED may be burn out.
5. LED module of 2 pcs (including more than 2 pcs), we suggest that different reels do not assemble together at the same module.
6. LED Pre-Bake Notice:
After the package opening over 168 hrs in 30°C, 60% RH or less. LED should be baked at 70±5°C / 24 hrs before using.
7. The design of Back Light Module (BLM) is proposed: LEDs and BLM's frame should keep 0.4 mm of distances, or insulate between them, in order to avoid shorting out.

Revision History

Rev	Major Change Since Last Revision	Date
1	New specification	2010/07/29