

# **DTL5053DWxxB3 Series**

## **TECHNICAL SPECIFICATION**

# DTL5053DWxxB3 Series Technical Specification

## ● Absolute Maximum Characteristics

The following table lists the product characteristics for the DTL5053DWxxB3 series package.

Characteristics	Unit	Minimum	Typical	Maximum
Power Dissipation	W			1.7
Thermal Resistance, Junction to Solder Point	°C/W		15	
Viewing Angle (FWHM)	degrees		120	
LED Junction Temperature	°C			115
DC Forward Current per Die	mA			150
DC Reverse Voltage per Die	V			5
Operating Temperature	°C	-40		85
Storage Temperature	°C	-40		100

## ● Electro-Optical Characteristics

The following table lists the product characteristics for the DTL5053DWxxB3 series package at  $I_f=120\text{mA}$  per die and  $T_j=25^\circ\text{C}$ .

Color	Part No.	CCT @ 360mA	Forward Voltage @ 360mA (V)			Luminous Flux @ 360mA (lm)		
		Typ	Min	Typ	Max	Min	Typ	Max
Cool White	DTL5053DW50B301	5000 K	2.8	3.2	3.8	80.6	95.0	114.0
	DTL5053DW57B301	5700 K						
Warm White	DTL5053DW27B301	2700 K	2.8	3.2	3.8	73.9	87.4	100.0
	DTL5053DW30B301	3000 K						
	DTL5053DW40B301	4000 K						

Notes:

1. We maintain a tolerance of  $\pm 10\%$  on flux and power measurements and  $\pm 5\%$  on CCT measurements.
2. The total luminous flux output is measured with an integrated sphere.
3. Correlated color temperature is derived from the CIE 1931 chromaticity diagram.
4. A tolerance of  $\pm 0.06\text{V}$  on forward voltage measurement.
5. Typical CRI is 75.
6. Flux and chromaticity are measured with each LED die connected to independent drive circuits at 120mA. The flux and chromaticity are measured with all LEDs lit simultaneously.

# DTL5053DWxxB3 Series Technical Specification

- Relative Spectrum of Emission ( $T_j = 25\text{ }^\circ\text{C}$ )

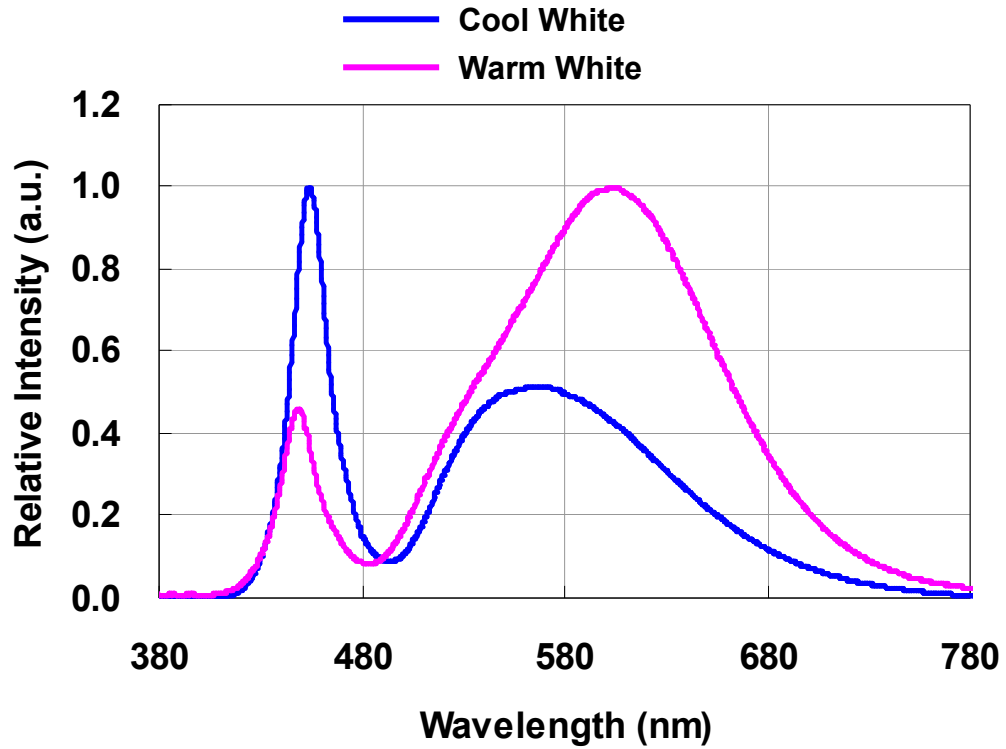

- Typical Spatial Radiation Pattern

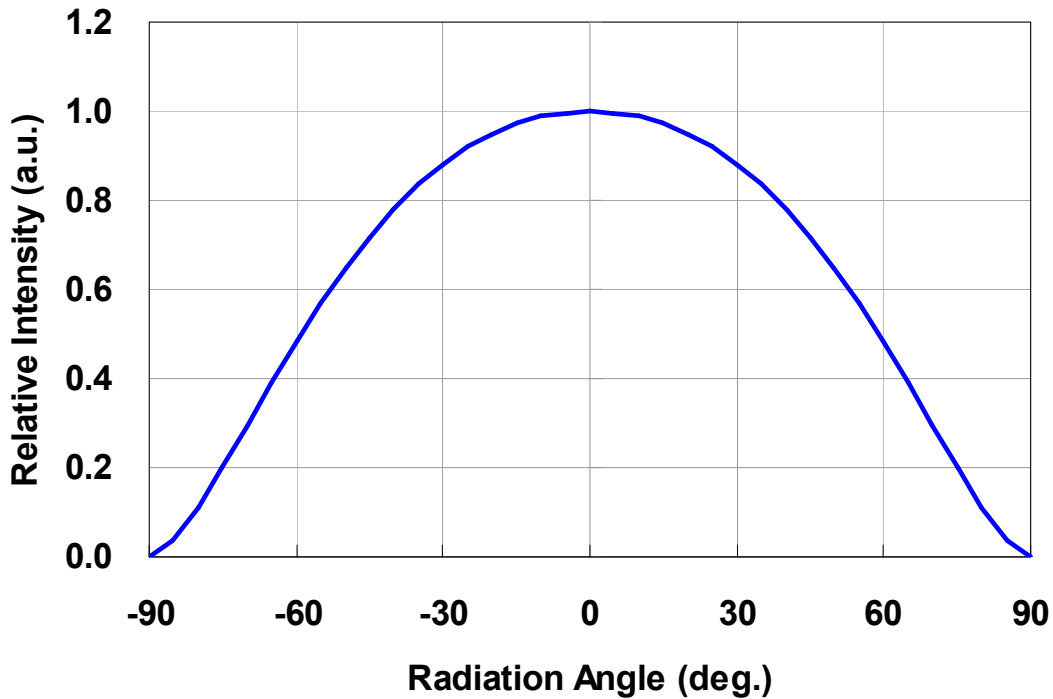

# DTL5053DWxxB3 Series Technical Specification

- Relative Luminous Flux vs. Current ( $T_j = 25\text{ }^\circ\text{C}$ )

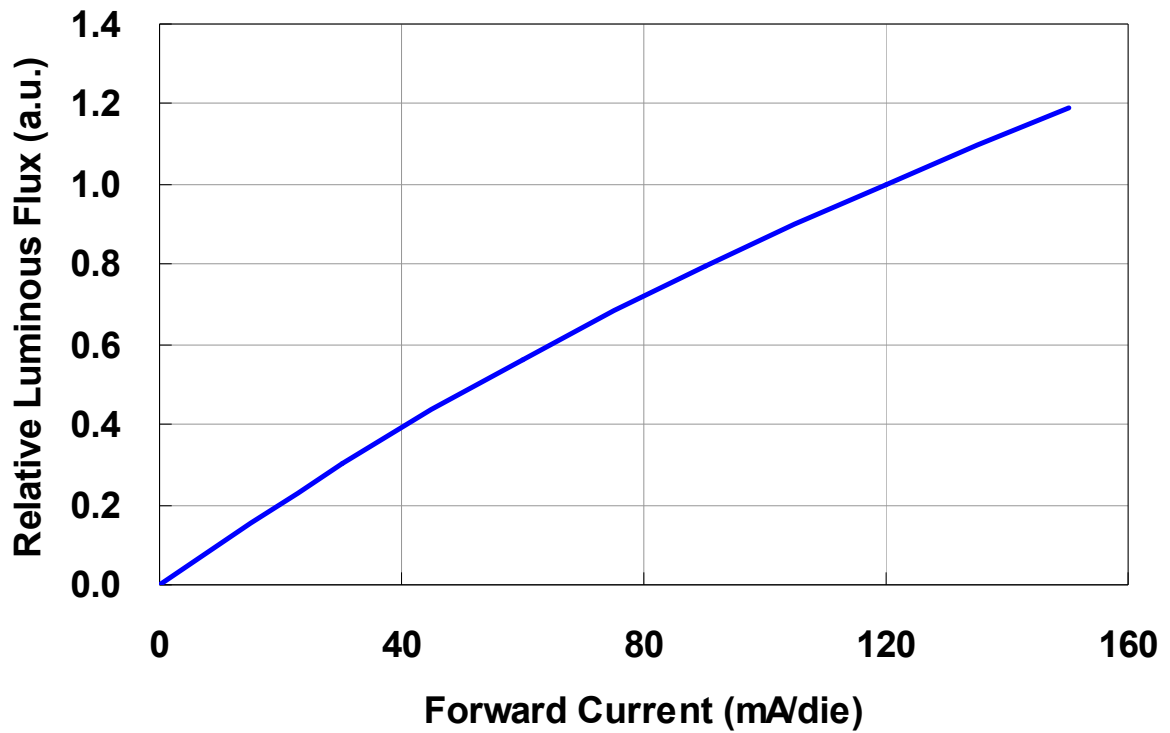

- Electrical Characteristics ( $T_j = 25\text{ }^\circ\text{C}$ )

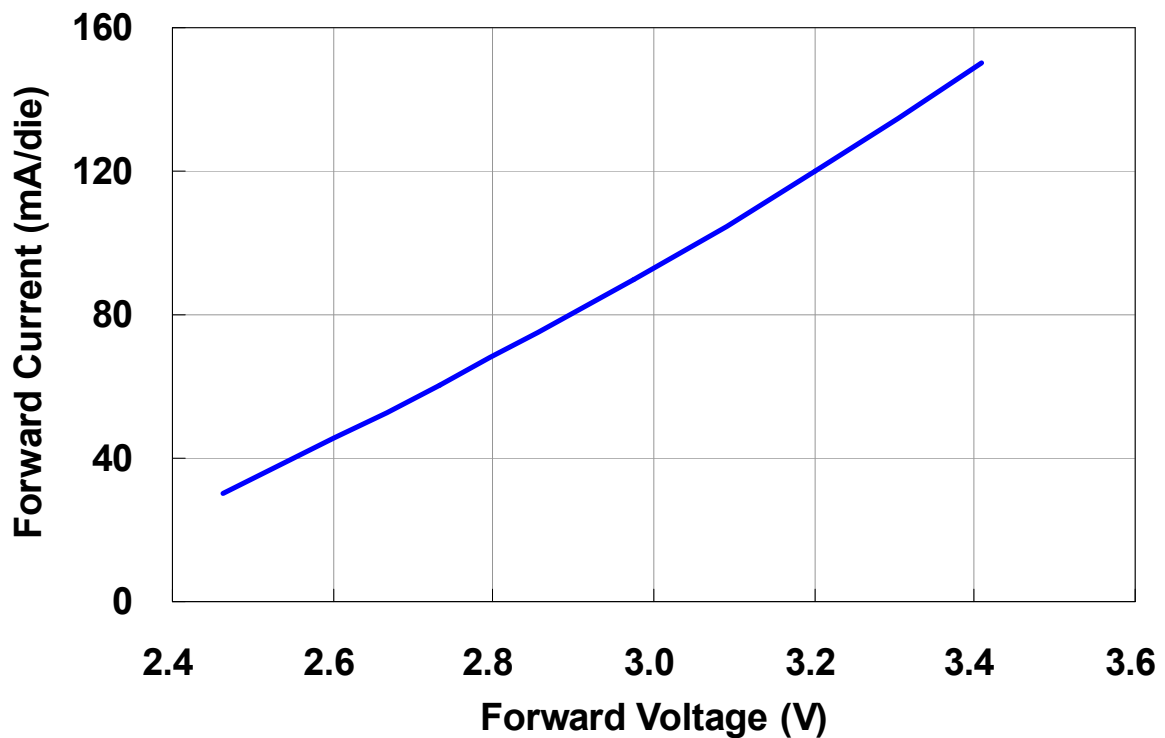

# DTL5053DWxxB3 Series Technical Specification

## ● Forward Current Derating Curve

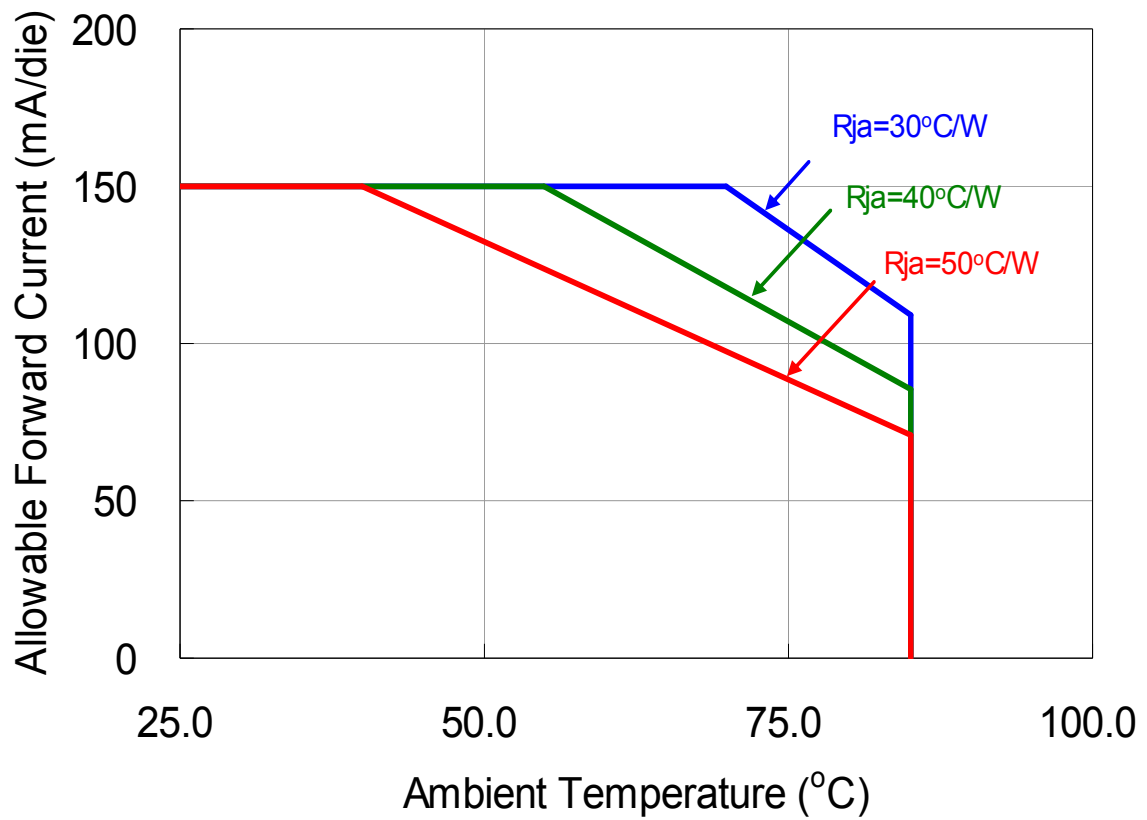

# DTL5053DWxxB3 Series Technical Specification

## ● Luminous Flux Categories

Color	Part No.	Code	Min. Luminous Flux @ 360 mA (lm)	Max. Luminous Flux @ 360 mA (lm)
Warm White	DTL5053DW27B301	S2	73.9	80.6
	DTL5053DW30B301	S3	80.6	87.4
	DTL5053DW40B301	T1	87.4	93.9
	DTL5053DW40B301	T2	93.9	100.0
Cool White	DTL5053DW50B301	S3	80.6	87.4
		T1	87.4	93.9
	DTL5053DW57B301	T2	93.9	100.0
		T3	100.0	107.0
		T4	107.0	114.0

### Notes:

1. The flux and chromaticity are measured with each LED die at driving current 120 mA.
2. The flux and chromaticity are measured with all LEDs lit simultaneously.
3. Luminous flux measurement allowance is  $\pm 10\%$ .

## ● Forward Voltage Categories

Color	Part No.	Code	Min. Forward Voltage @ 360 mA (lm)	Max. Forward Voltage @ 360 mA (lm)
Cool White	DTL5053DW27B301	U28	2.80	3.00
	DTL5053DW30B301	U30	3.00	3.20
Warm White	DTL5053DW40B301	U32	3.20	3.40
	DTL5053DW50B301	U34	3.40	3.60
	DTL5053DW57B301	U36	3.60	3.80

### Notes:

1. The forward voltage is measured with each LED die at driving current 120 mA.
2. The forward voltage measurement allowance is  $\pm 0.1V$ .

# DTL5053DWxxB3 Series Technical Specification

## ● Chromaticity Coordinate Categories

Code	x	y	Code	x	y	Code	x	y	Code	x	y
0A	0.2950	0.2970	0B	0.2920	0.3060	0C	0.2984	0.3133	0D	0.2984	0.3133
	0.2920	0.3060		0.2895	0.3135		0.2962	0.3220		0.3048	0.3207
	0.2984	0.3133		0.2962	0.3220		0.3028	0.3304		0.3068	0.3113
	0.3009	0.3042		0.2984	0.3133		0.3048	0.3207		0.3009	0.3042
0R	0.2980	0.2880	0S	0.2895	0.3135	0T	0.2962	0.3220	0U	0.3037	0.2937
	0.2950	0.2970		0.2870	0.3210		0.2937	0.3312		0.3009	0.3042
	0.3009	0.3042		0.2937	0.3312		0.3005	0.3415		0.3068	0.3113
	0.3037	0.2937		0.2962	0.3220		0.3028	0.3304		0.3093	0.2993
1A	0.3048	0.3207	1B	0.3028	0.3304	1C	0.3115	0.3391	1D	0.3130	0.3290
	0.3130	0.3290		0.3115	0.3391		0.3205	0.3481		0.3213	0.3373
	0.3144	0.3186		0.3130	0.3290		0.3213	0.3373		0.3221	0.3261
	0.3068	0.3113		0.3048	0.3207		0.3130	0.3290		0.3144	0.3186
1R	0.3068	0.3113	1S	0.3005	0.3415	1T	0.3099	0.3509	1U	0.3144	0.3186
	0.3144	0.3186		0.3099	0.3509		0.3196	0.3602		0.3221	0.3261
	0.3161	0.3059		0.3115	0.3391		0.3205	0.3481		0.3231	0.3120
	0.3093	0.2993		0.3028	0.3304		0.3115	0.3391		0.3161	0.3059
2A	0.3215	0.3350	2B	0.3207	0.3462	2C	0.3290	0.3538	2D	0.2984	0.3133
	0.3290	0.3417		0.3290	0.3538		0.3376	0.3616		0.3371	0.3490
	0.3290	0.3300		0.3290	0.3417		0.3371	0.3490		0.3366	0.3369
	0.3222	0.3243		0.3215	0.3350		0.3290	0.3417		0.3290	0.3300
2R	0.3222	0.3243	2S	0.3196	0.3602	2T	0.3290	0.3690	2U	0.3290	0.3300
	0.3290	0.3300		0.3290	0.3690		0.3381	0.3762		0.3366	0.3369
	0.3290	0.3180		0.3290	0.3538		0.3376	0.3616		0.3361	0.3245
	0.3231	0.3120		0.3207	0.3462		0.3290	0.3538		0.3290	0.3180
3A	0.3371	0.3490	3B	0.3376	0.3616	3C	0.3463	0.3687	3D	0.3451	0.3554
	0.3451	0.3554		0.3463	0.3687		0.3551	0.3760		0.3533	0.3620
	0.3440	0.3427		0.3451	0.3554		0.3533	0.3620		0.3515	0.3487
	0.3366	0.3369		0.3371	0.3490		0.3451	0.3554		0.3440	0.3427
3R	0.3366	0.3369	3S	0.3381	0.3762	3T	0.3480	0.3840	3U	0.3440	0.3428
	0.3440	0.3428		0.3480	0.3840		0.3571	0.3907		0.3515	0.3487
	0.3429	0.3307		0.3463	0.3687		0.3551	0.3760		0.3495	0.3339
	0.3361	0.3245		0.3376	0.3616		0.3463	0.3687		0.3429	0.3307
4A	0.2950	0.2970	4B	0.2920	0.3060	4C	0.2984	0.3133	4D	0.2984	0.3133
	0.2920	0.3060		0.2895	0.3135		0.2962	0.3220		0.3048	0.3207
	0.2984	0.3133		0.2962	0.3220		0.3028	0.3304		0.3068	0.3113
	0.3009	0.3042		0.2984	0.3133		0.3048	0.3207		0.3009	0.3042
4R	0.2980	0.2880	4S	0.2895	0.3135	4T	0.2962	0.3220	4U	0.3037	0.2937
	0.2950	0.2970		0.2870	0.3210		0.2937	0.3312		0.3009	0.3042
	0.3009	0.3042		0.2937	0.3312		0.3005	0.3415		0.3068	0.3113
	0.3037	0.2937		0.2962	0.3220		0.3028	0.3304		0.3093	0.2993

# DTL5053DWxxB3 Series Technical Specification

Code	x	y	Code	x	y	Code	x	y	Code	x	y
5A1	0.3670	0.3578	5A2	0.3686	0.3649	5A3	0.3744	0.3685	5A4	0.3726	0.3612
	0.3686	0.3649		0.3702	0.3722		0.3763	0.3760		0.3744	0.3685
	0.3744	0.3685		0.3763	0.3760		0.3825	0.3798		0.3804	0.3721
	0.3726	0.3612		0.3744	0.3685		0.3804	0.3721		0.3783	0.3646
5B1	0.3702	0.3722	5B2	0.3719	0.3797	5B3	0.3782	0.3837	5B4	0.3763	0.3760
	0.3719	0.3797		0.3736	0.3874		0.3802	0.3916		0.3782	0.3837
	0.3782	0.3837		0.3802	0.3916		0.3869	0.3958		0.3847	0.3877
	0.3763	0.3760		0.3782	0.3837		0.3847	0.3877		0.3825	0.3798
5C1	0.3825	0.3798	5C2	0.3847	0.3877	5C3	0.3912	0.3917	5C4	0.3887	0.3836
	0.3847	0.3877		0.3869	0.3958		0.3937	0.4001		0.3912	0.3917
	0.3912	0.3917		0.3937	0.4001		0.4006	0.4044		0.3978	0.3958
	0.3887	0.3836		0.3912	0.3917		0.3978	0.3958		0.3950	0.3875
5D1	0.3783	0.3646	5D2	0.3804	0.3721	5D3	0.3863	0.3758	5D4	0.3840	0.3681
	0.3804	0.3721		0.3825	0.3798		0.3887	0.3836		0.3863	0.3758
	0.3863	0.3758		0.3887	0.3836		0.3950	0.3875		0.3924	0.3794
	0.3840	0.3681		0.3863	0.3758		0.3924	0.3794		0.3898	0.3716
6A1	0.3889	0.3690	6A2	0.3915	0.3768	6A3	0.3981	0.3800	6A4	0.3953	0.3720
	0.3915	0.3768		0.3941	0.3848		0.4010	0.3882		0.3981	0.3800
	0.3981	0.3800		0.4010	0.3882		0.4080	0.3916		0.4048	0.3832
	0.3953	0.3720		0.3981	0.3800		0.4048	0.3832		0.4017	0.3751
6B1	0.3941	0.3848	6B2	0.3968	0.3930	6B3	0.4040	0.3966	6B4	0.4010	0.3882
	0.3968	0.3930		0.3996	0.4015		0.4071	0.4052		0.4040	0.3966
	0.4040	0.3966		0.4071	0.4052		0.4146	0.4089		0.4113	0.4001
	0.4010	0.3882		0.4040	0.3966		0.4113	0.4001		0.4080	0.3916
6C1	0.4080	0.3916	6C2	0.4113	0.4001	6C3	0.4186	0.4037	6C4	0.4150	0.3950
	0.4113	0.4001		0.4146	0.4089		0.4222	0.4127		0.4186	0.4037
	0.4186	0.4037		0.4222	0.4127		0.4299	0.4165		0.4259	0.4073
	0.4150	0.3950		0.4186	0.4037		0.4259	0.4073		0.4221	0.3984
6D1	0.4017	0.3751	6D2	0.4048	0.3832	6D3	0.4116	0.3865	6D4	0.4082	0.3782
	0.4048	0.3832		0.4080	0.3916		0.4150	0.3950		0.4116	0.3865
	0.4116	0.3865		0.4150	0.3950		0.4221	0.3984		0.4183	0.3898
	0.4082	0.3782		0.4116	0.3865		0.4183	0.3898		0.4147	0.3814
7A1	0.4147	0.3814	7A2	0.4183	0.3898	7A3	0.4242	0.3919	7A4	0.4203	0.3833
	0.4183	0.3898		0.4221	0.3984		0.4281	0.4006		0.4242	0.3919
	0.4242	0.3919		0.4281	0.4006		0.4342	0.4028		0.4300	0.3939
	0.4203	0.3833		0.4242	0.3919		0.4300	0.3939		0.4259	0.3853
7B1	0.4221	0.3984	7B2	0.4259	0.4073	7B3	0.4322	0.4096	7B4	0.4281	0.4006
	0.4259	0.4073		0.4299	0.4165		0.4364	0.4188		0.4322	0.4096
	0.4322	0.4096		0.4364	0.4188		0.4430	0.4212		0.4385	0.4119
	0.4281	0.4006		0.4322	0.4096		0.4385	0.4119		0.4342	0.4028

# DTL5053DWxxB3 Series Technical Specification

Code	x	y	Code	x	y	Code	x	y	Code	x	y
7C1	0.4342	0.4028	7C2	0.4385	0.4119	7C3	0.4449	0.4141	7C4	0.4403	0.4049
	0.4385	0.4119		0.4430	0.4212		0.4496	0.4236		0.4449	0.4141
	0.4449	0.4141		0.4496	0.4236		0.4562	0.4260		0.4513	0.4164
	0.4403	0.4049		0.4449	0.4141		0.4513	0.4164		0.4465	0.4071
7D1	0.4259	0.3853	7D2	0.4300	0.3939	7D3	0.4359	0.3960	7D4	0.4316	0.3873
	0.4300	0.3939		0.4342	0.4028		0.4403	0.4049		0.4359	0.3960
	0.4359	0.3960		0.4403	0.4049		0.4465	0.4071		0.4418	0.3981
	0.4316	0.3873		0.4359	0.3960		0.4418	0.3981		0.4373	0.3893
8A1	0.4373	0.3893	8A2	0.4418	0.3981	8A3	0.4475	0.3994	8A4	0.4428	0.3906
	0.4418	0.3981		0.4465	0.4071		0.4523	0.4085		0.4475	0.3994
	0.4475	0.3994		0.4523	0.4085		0.4582	0.4099		0.4532	0.4008
	0.4428	0.3906		0.4475	0.3994		0.4532	0.4008		0.4483	0.3919
8B1	0.4465	0.4071	8B2	0.4513	0.4164	8B3	0.4573	0.4178	8B4	0.4523	0.4085
	0.4513	0.4164		0.4562	0.4260		0.4624	0.4274		0.4573	0.4178
	0.4573	0.4178		0.4624	0.4274		0.4687	0.4289		0.4634	0.4193
	0.4523	0.4085		0.4573	0.4178		0.4634	0.4193		0.4582	0.4099
8C1	0.4582	0.4099	8C2	0.4634	0.4193	8C3	0.4695	0.4207	8C4	0.4641	0.4112
	0.4634	0.4193		0.4687	0.4289		0.4750	0.4304		0.4695	0.4207
	0.4695	0.4207		0.4750	0.4304		0.4813	0.4319		0.4756	0.4221
	0.4641	0.4112		0.4695	0.4207		0.4756	0.4221		0.4700	0.4126
8D1	0.4483	0.3919	8D2	0.4532	0.4008	8D3	0.4589	0.4021	8D4	0.4538	0.3931
	0.4532	0.4008		0.4582	0.4099		0.4641	0.4112		0.4589	0.4021
	0.4589	0.4021		0.4641	0.4112		0.4700	0.4126		0.4646	0.4034
	0.4538	0.3931		0.4589	0.4021		0.4646	0.4034		0.4593	0.3944

**Notes:**

1. The value is all dies operated performance at driving current 120 mA.
2. The chromaticity coordinates (x, y) is derived from the CIE 1931 chromaticity diagram.
3. IS CAS 140B is for the luminous flux and the CIE 1931 chromaticity coordinates (x, y) testing.  
The chromaticity coordinates (x, y) guarantee should be added  $\pm 0.005$  tolerance.

# DTL5053DWxxB3 Series Technical Specification

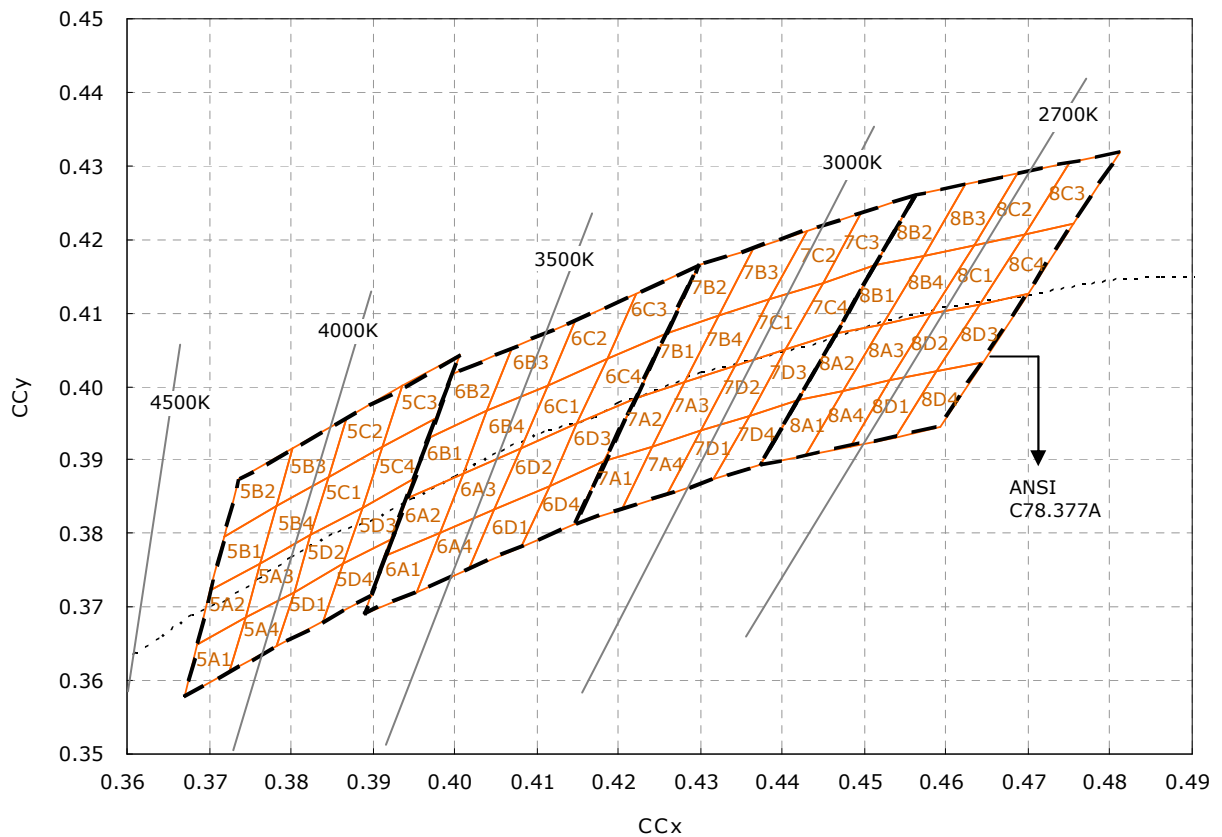
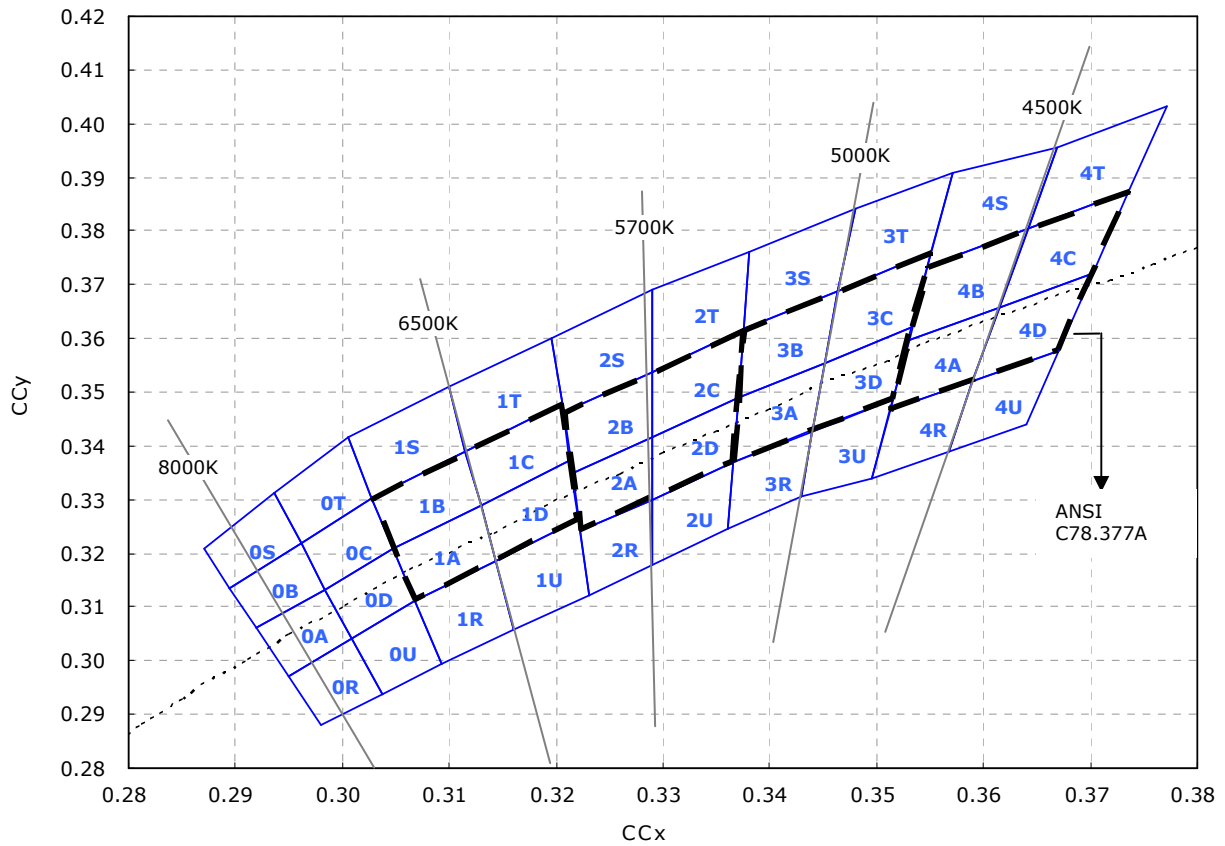

# DTL5053DWxxB3 Series Technical Specification

## ● Pre-Release Qualification Test List (Operating Life Tests)

Test	Applicable Standards	Test Conditions & Failure Criteria
Room Temperature Operating Life Test (RTOL)	JESD22 Method A108-C	<b>Test Conditions:</b> <ul style="list-style-type: none"> <li>• Ambient temperature : 25°C</li> <li>• Forward current : 120 mA per die</li> <li>• Test period : 1000 hours</li> </ul> <b>Failure Criteria 1 :</b> <ul style="list-style-type: none"> <li>• Forward voltage shift <sub>2</sub> : &gt; U.S.L x 10%</li> <li>• Luminous flux degradation <sub>2</sub> : &gt; L.S.L. x 30%</li> <li>• Catastrophic failure <sub>3</sub></li> </ul>
Wet High Temperature Operating Life Test (WHTOL)		<b>Test Conditions:</b> <ul style="list-style-type: none"> <li>• Forward current : 50 mA per die</li> <li>• Ambient temperature : 85°C</li> <li>• Humidity : 85% relative humidity (RH)</li> <li>• Time : 1000 hours</li> </ul> <b>Failure Criteria 1 :</b> <ul style="list-style-type: none"> <li>• Forward voltage shift <sub>2</sub> : &gt; U.S.L x 10%</li> <li>• Luminous flux degradation <sub>2</sub> : &gt; L.S.L. x 30%</li> <li>• Catastrophic failure <sub>3</sub></li> </ul>

Notes:

1. The entire test has failed if one LED (or more) from the sample set satisfy the listed failure criteria. If no LED satisfies the listed failure criteria, the test is successful.
2. Comparison is made between [value at time 0] and [value at the end of the test period].
3. A catastrophic failure is a failure that causes the LED to become non-functional (i.e., open or short).

## ● Pre-Release Qualification Test List (Non-Operating Life Tests)

Test	Applicable Standards	Test Conditions & Failure Criteria
Thermal Cycle	MIL-STD-202G Method 107G	<b>Test Conditions:</b> <ul style="list-style-type: none"> <li>• Temperature range : -40°C to 100°C</li> <li>• Dwell time : 30 minutes</li> <li>• Transfer time : 5 minutes</li> <li>• Cycles : 500 cycles</li> </ul> <b>Failure Criteria 1 :</b> <ul style="list-style-type: none"> <li>• LED no longer lights up after test</li> </ul>
Thermal Shock		<b>Test Conditions:</b> <ul style="list-style-type: none"> <li>• Temperature range : -55°C to 105°C</li> <li>• Dwell time : 15 minutes</li> <li>• Transfer time : &lt; 10 seconds</li> <li>• Cycles : 500 cycles</li> </ul> <b>Failure Criteria 1 :</b> <ul style="list-style-type: none"> <li>• LED no longer lights up after test</li> </ul>
Moisture Resistance Cyclic		<b>Test Conditions:</b> <ul style="list-style-type: none"> <li>• Temperature range : -65°C / -10°C / 25°C</li> <li>• Dwell time : 12 hours</li> <li>• Transfer time : &lt; 10 seconds</li> <li>• Humidity : 90% relative humidity (RH)</li> <li>• Cycles : 10 cycles</li> </ul> <b>Failure Criteria 1 :</b> <ul style="list-style-type: none"> <li>• LED no longer lights up after test</li> </ul>
High Temperature Storage		<b>Test Conditions:</b> <ul style="list-style-type: none"> <li>• Ambient temperature : 100°C</li> <li>• Time : 1000 hours</li> </ul> <b>Failure Criteria 1 :</b> <ul style="list-style-type: none"> <li>• Forward voltage shift <sub>2</sub> : &gt; U.S.L x 10%</li> <li>• Luminous flux degradation <sub>2</sub> : &gt; L.S.L. x 30%</li> <li>• Catastrophic failure <sub>3</sub></li> </ul>
Low Temperature Storage		<b>Test Conditions:</b> <ul style="list-style-type: none"> <li>• Ambient temperature : -40°C</li> <li>• Time : 1000 hours</li> </ul> <b>Failure Criteria 1 :</b> <ul style="list-style-type: none"> <li>• Forward voltage shift <sub>2</sub> : &gt; U.S.L x 10%</li> <li>• Luminous flux degradation <sub>2</sub> : &gt; L.S.L. x 30%</li> <li>• Catastrophic failure <sub>3</sub></li> </ul>

Notes:

1. The entire test has failed if one LED (or more) from the sample set satisfy the listed failure criteria. If no LED satisfies the listed failure criteria, the test is successful.

# DTL5053DWxxB3 Series Technical Specification

## ● Reflow Soldering Characteristics

In testing, we have found LEDs to be compatible with JEDEC J-STD-020C, using the parameters listed below. As a general guideline, we recommend that users follow the recommended soldering profile provided by the manufacturer of solder paste used.

Note that this general guideline may not apply to all PCB designs and configurations of reflow soldering equipment.

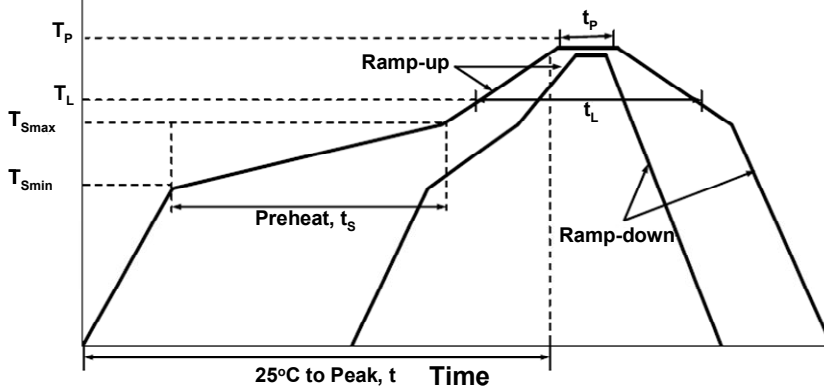

Profile Feature	Lead-Based Solder	Lead-Free Solder
Average Ramp-Up Rate (T <sub>Smax</sub> to T <sub>p</sub> )	3°C/second max.	3°C/second max.
Preheat: Temperature Min (T <sub>Smin</sub> )	100°C	150°C
Preheat: Temperature Max (T <sub>Smax</sub> )	150°C	200°C
Preheat: Time (t <sub>Smin</sub> to t <sub>Smax</sub> )	60-120 seconds	60-180 seconds
Time Maintained Above: Temperature (T <sub>L</sub> )	183°C	217°C
Time Maintained Above: Time (t <sub>L</sub> )	60-150 seconds	60-150 seconds
Peak/Classification Temperature (T <sub>p</sub> )	215°C	260°C
Time Within 5°C of Actual Peak Temperature (t <sub>p</sub> )	10-30 seconds	20-40 seconds
Ramp-Down Rate	6°C/second max.	6°C/second max.
Time 25°C to Peak Temperature	6 minutes max.	8 minutes max.

Note: All temperatures refer to topside of the package, measured on the package body surface.

# DTL5053DWxxB3 Series Technical Specification

## ● Mechanical Dimensions

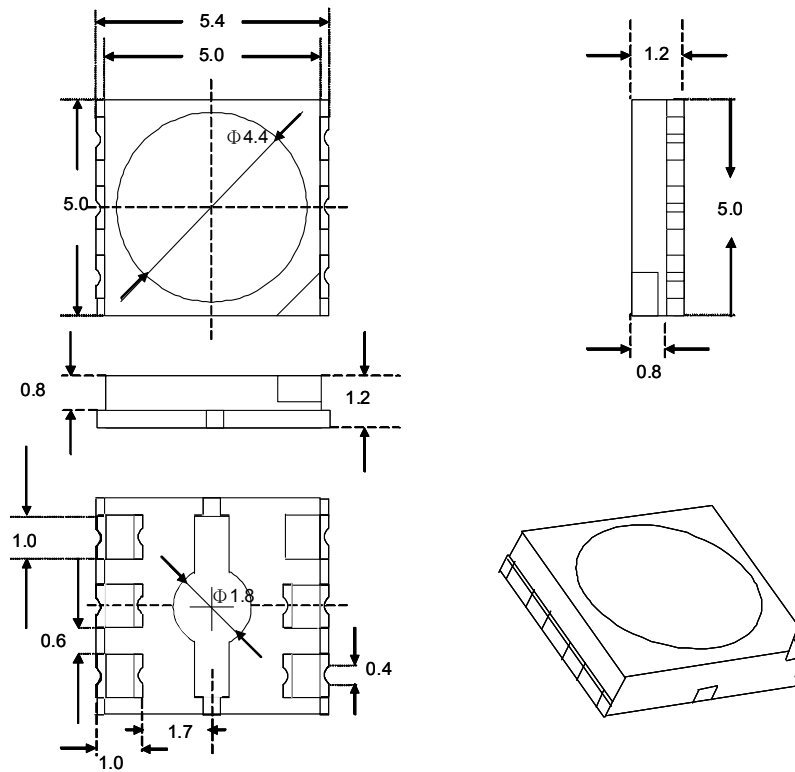

Notes:

1. All dimensions are in millimeters.
2. Tolerance:  $\pm 0.2$  mm unless otherwise noted.

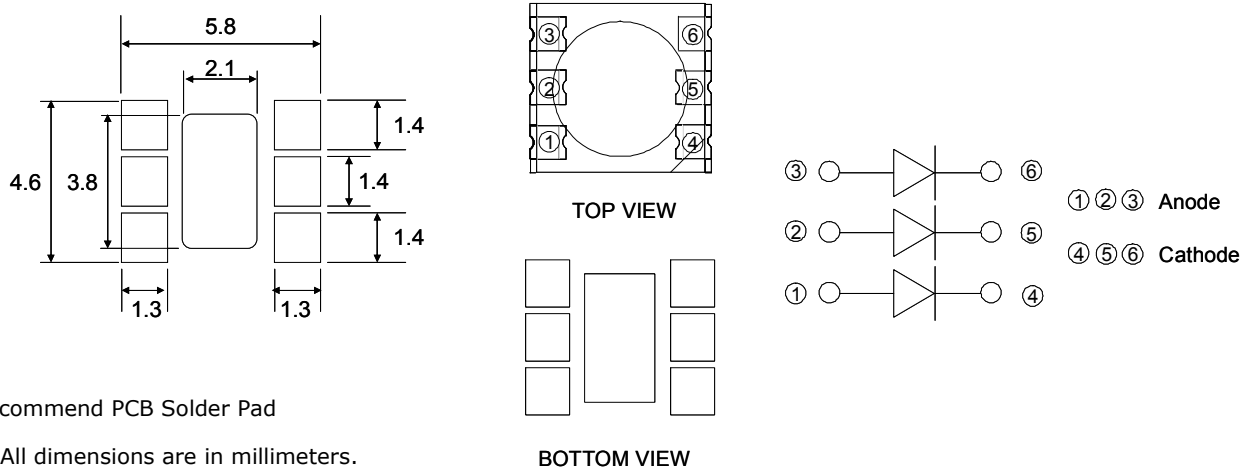

Recommend PCB Solder Pad

1. All dimensions are in millimeters.
2. Tolerance:  $\pm 0.2$  mm unless otherwise noted

# DTL5053DWxxB3 Series Technical Specification

## ● Package Dimensions of Tape and Reel

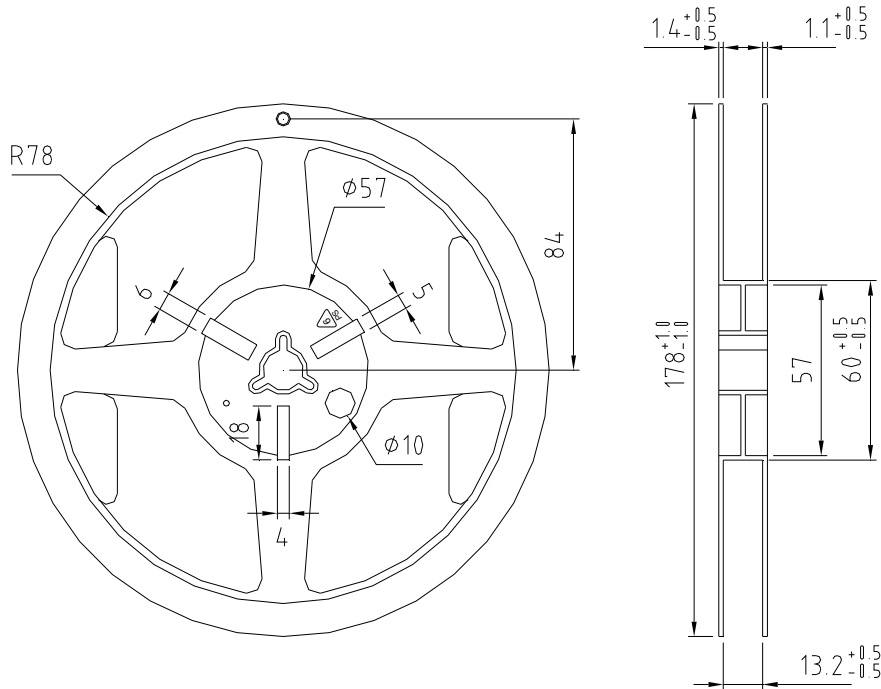
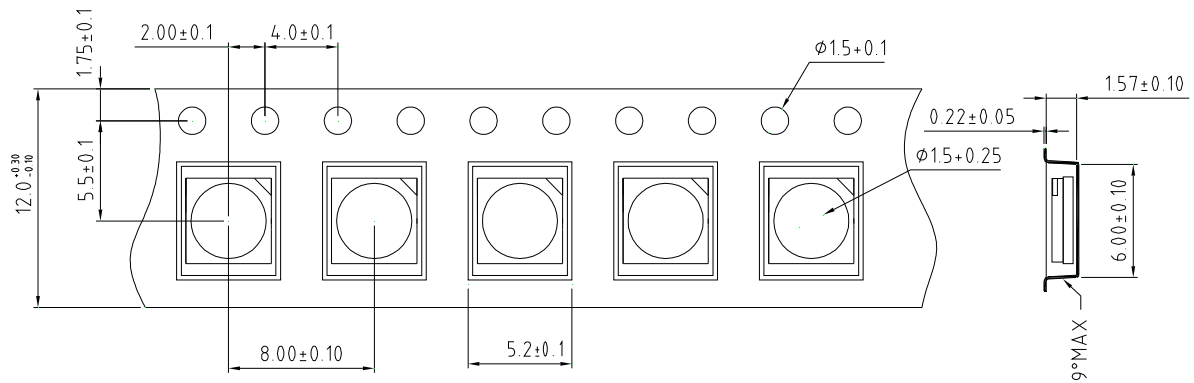

### Notes:

1. Empty component pockets sealed with top cover tape.
2. 1400 pieces per one 7-inch reel.
3. In accordance with EIA-481-1-L23 specifications.

# DTL5053DWxxB3 Series Technical Specification

---

## ● Notes

### Storage Conditions

The product is qualified as Moisture Sensitive Level 4 per JEDEC J-STD-020 Precaution when handling this moisture sensitive product is important to ensure the reliability of the product.

The package is sealed:

The LEDs should be stored at 30°C or less and 90%RH or less. And the LEDs are limited to use within one year, while the LEDs is packed in moisture-proof package with the desiccants inside.

The package is opened:

The LEDs should be stored at 30°C or less and 60%RH or less. Moreover, the LEDs are limited to solder process within 72 hours. If the Humidity Indicator shows the pink color in 30% even higher or exceed the storage limiting time since opened, that we recommended to be with workable desiccants in original package.

### ESD (Electrostatic Discharge)

Static electricity or power surge will damage the LEDs. Suggestions to prevent ESD damage:

- Use a conductive wrist band or anti-electrostatic glove when handling these LEDs.
- All devices, equipment, and machinery must be properly grounded.
- Work tables, storage racks, etc. should be properly grounded.
- Use ion blower to neutralize the static charge which might have built up on surface of the LED's plastic lens as a result of friction between LEDs during storage and handling.

ESD-damaged LEDs will exhibit abnormal characteristics such as high reverse leakage current, low forward voltage, or "no light up" at low currents. To verify for ESD damage, check for "light up" and  $V_F$  of the suspect LEDs at low current. The  $V_F$  of "good" LEDs should be  $>2.0@0.1mA$  for InGaN product.

### Suggested Checking List

#### Static-Safe Workstation & Work Areas

- Static-safe working stations or work-areas have ESD signs.
- All surfaces and objects at all static-safe workstation and within 1 ft measure less than 100V
- All ionizer activated, positioned towards the units.
- Each work surface mats grounding is good.

#### Personnel Grounding

- Every person (including visitors) handling ESD sensitive (ESDS) items wear wrist strap, heel strap or conductive shoes with conductive flooring.
- If conductive footwear used, conductive flooring also present.
- Garments, hairs or anything closer than 1 ft to ESD items measure less than 100V.
- The wrist strap or heel strap / conductive shoes are checked daily and result recorded.
- All wrist strap or heel strap checkers calibration up to date.

#### Device Handling

- Each ESDS items identified by EIA-471 labels on item or packaging.
- No static charge generators (e.g. plastics) including containers with ESDS items.
- All flexible conductive and dissipative package materials are inspected before reuse or recycles.